

SERVICE BULLETIN

SUBARU 360 SERIES

NO. UK69-2

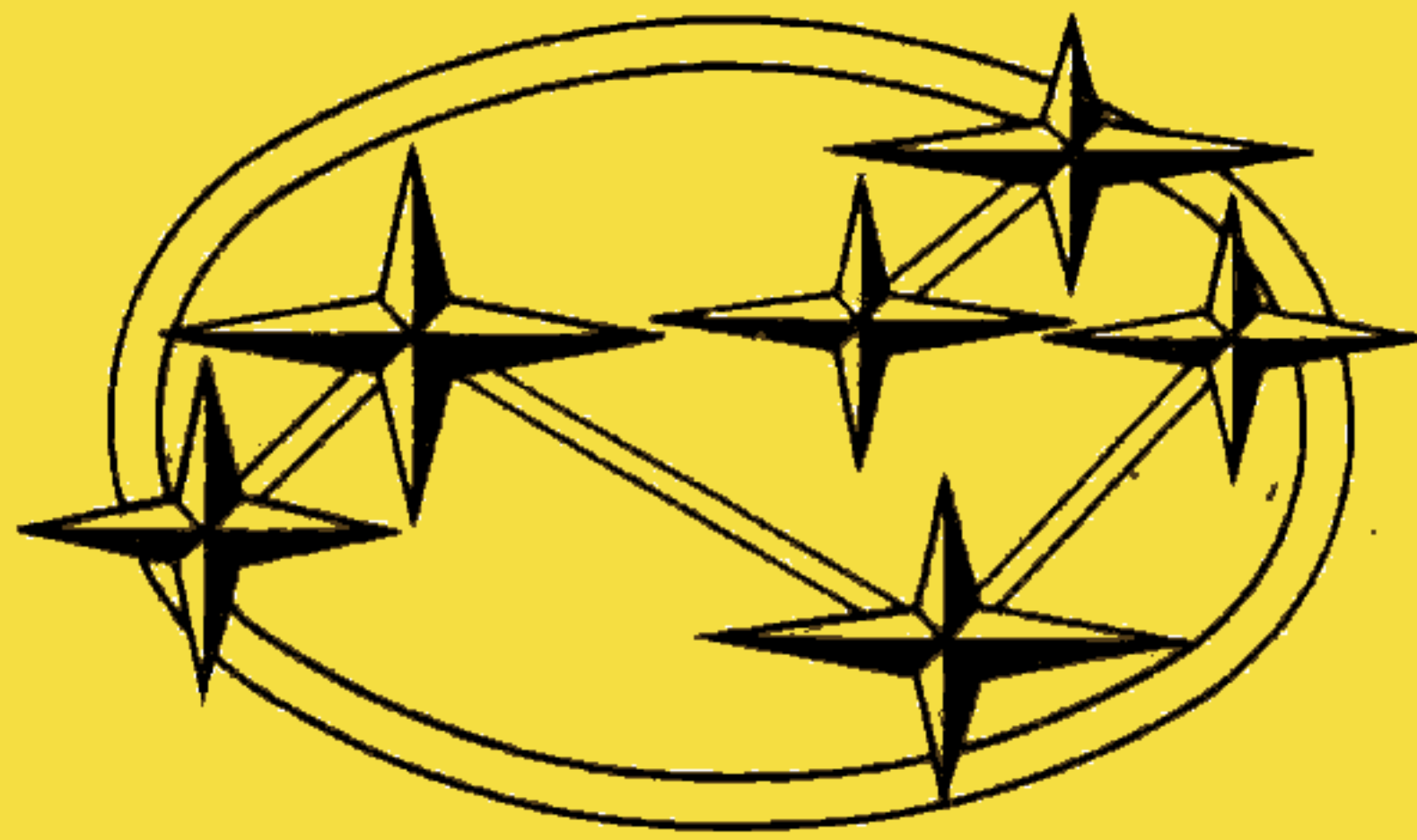

JUNE 1969

 **FUJI HEAVY INDUSTRIES LTD.**

APPLICABLE MODEL	
SUBARU 360	Sedan
"	Young S
"	Auto-clutch
"	Truck
"	Van

The crankshaft and its related parts have been modified.

1. DETAILS OF MODIFICATION

(1) CRANKCASE

The sleeves casted in the crankcase for the main bearings have been abolished.

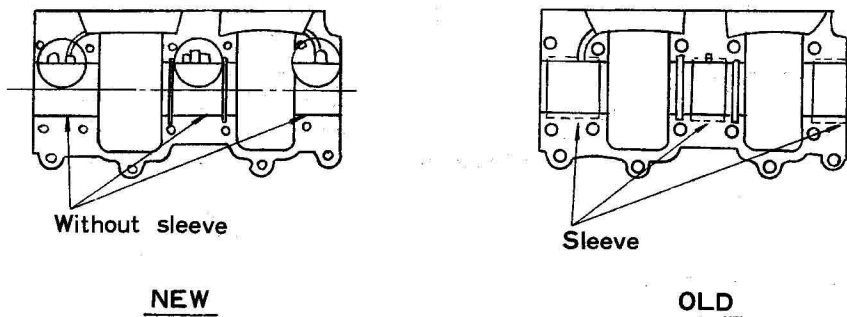

(2) CRANKSHAFT ASSEMBLY

(a) Crankshaft III (Clutch side)

Depth and Shape of key groove for woodruff key have been changed.

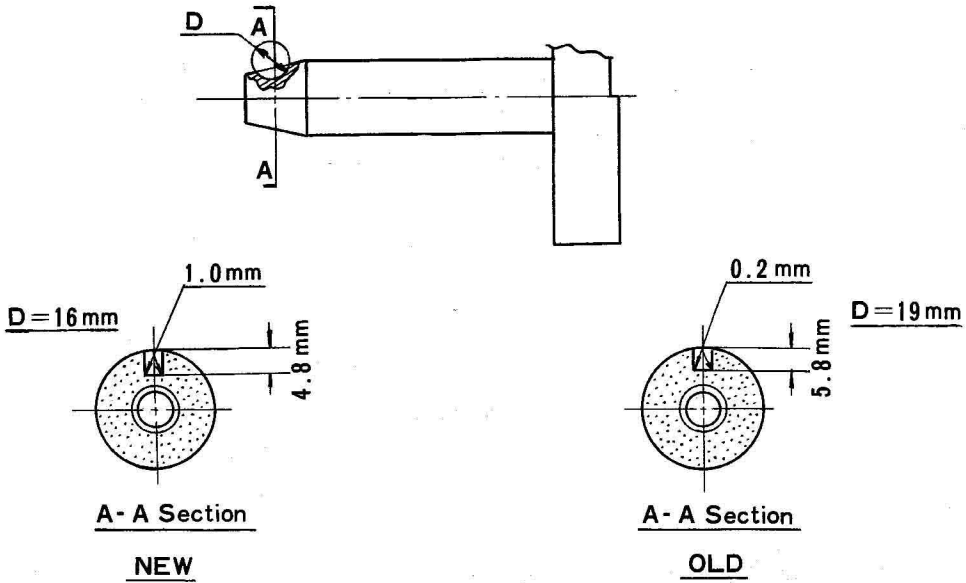

(b) Woodruff Key

Size and Shape of Woodruff Key have been changed.

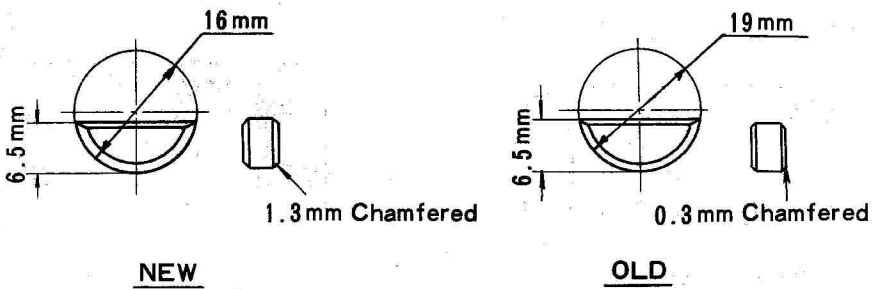

(c) Connecting Rod:

- (1) Width of the small end has been changed.
- (2) Oil grooves on the big end have been abolished.

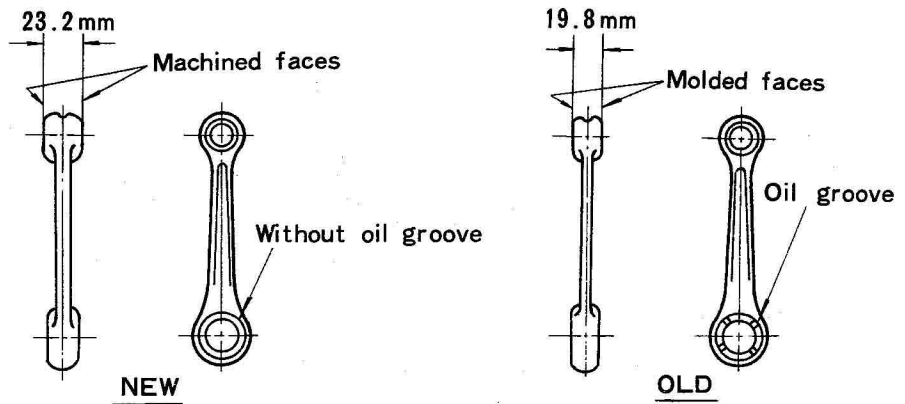

(d) Washer (Connecting rod big end)

Washer has been changed to round shape from square shape.

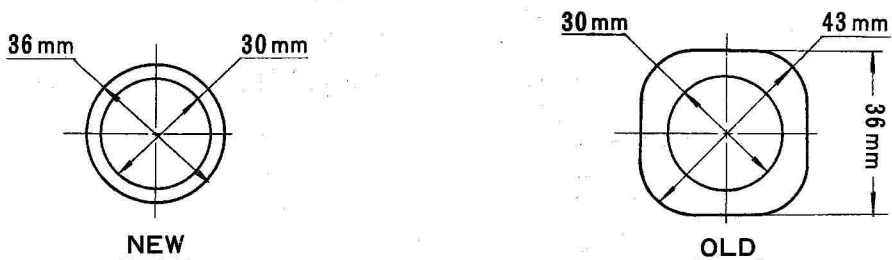

(e) Ball bearing

Groove has been added on the outer race.

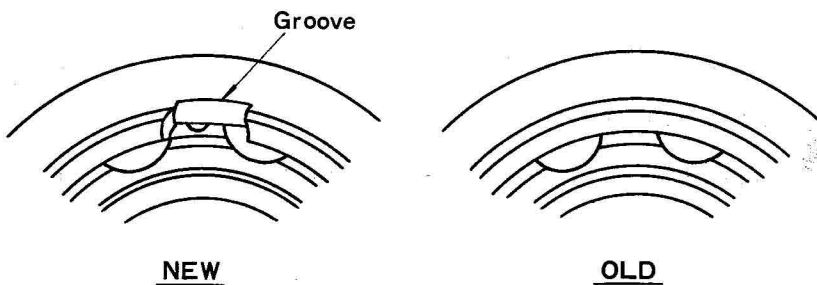

(f) Stopper ring

The stopper rings have been newly added.

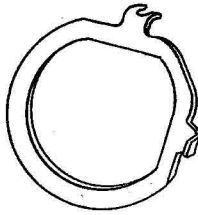

(g) Oil seal

Width of the oil seal has been changed.

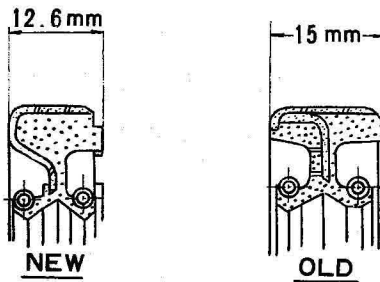

(h) Labyrinth packing

Width and shape of the labyrinth packing have been changed.

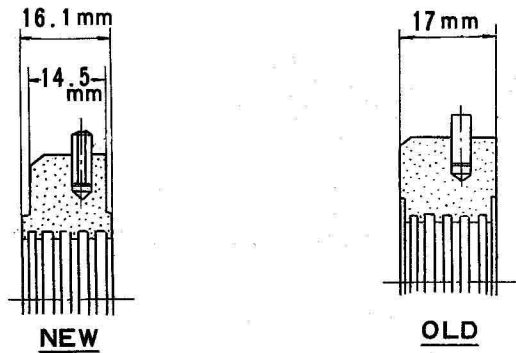

(i) Straight pin

Shape of the straight pin has been changed.

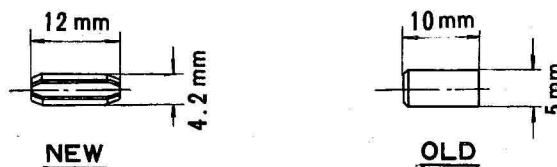

(3) PISTON (#1 & #2)

Inside of the piston pin bosses have been machined in order to keep the proper clearance.

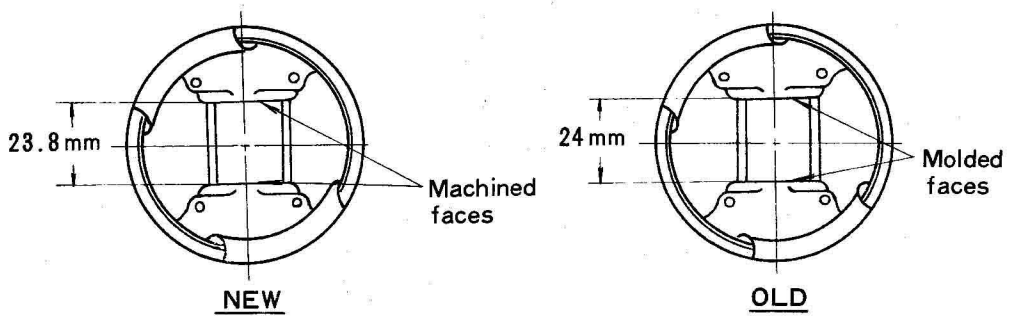

(4) NEEDLE BEARING (CONNECTING ROD SMALL END)

Numbers of roller has been changed to 14 from 16.

2. APPLICABLE ENGINE NUMBER AND INTERCHANGEABILITY

No.	Nomenclature	Part Number		Applicable engine number	Interchangeability
		New	Old		
1	Crankcase	880045010	880045000	749335 and after	None
		880045110	880045100	737464 and after	
		880045910	880045900	Truck: 755023 and after Van: 747192 and after	
2	Crankshaft Assy	810297200	810295010	749335 and after	Same as above
		810297200	810295010	Truck: 755023 and after Van: 747192 - 754877	
		810297300	810295910	737464 and after	
		810297200	810295110	754878 and after	
3	Crankshaft III	813036800	813030120	747192 and after	None
		813037300	813030320		
		804505040	053205400		
4	Woodruff Key	813345200	813341120	749335 and after	None
5	Connecting Rod	803030020	803030010	749335 and after	None
7	Ball Bearing	806230010	060562060	Sedan, YS: 749335 and after Auto-clutch: 737464 and after	None
		806230020	060862060	Truck: 755023 and after Van: 747192 and after	
8	Stopper Ring	811445100	—	Sedan, YS: 749335 and after Auto-clutch: 737464 and after Truck: 755023 and after Van: 747192 and after	None
9	Oil Seal	806735060	806735050	Sedan, YS: 749335 and after Auto-clutch: 737464 and after Truck: 755023 and after Van: 747192 and after	None
10	Labyrinth Packing	820475100	820475000	Sedan, YS: 749335 and after Auto-clutch: 737464 and after Truck: 755023 and after Van: 747192 and after	None

No.	Nomenclature	Part Number		Applicable engine number	Interchangeability
		New	Old		
11	Straight Pin	804004130	806105020	Sedan, YS: 749335 and after Auto-clutch: 737464 and after Truck: 755023 and after Van: 747192 and after	None
12	Piston Set I	880056007	881255000	749335 and after	New Yes ↑ ↓ None Old
	Piston Set II	880066007	881265000		
13	Needle Bearing (small end)	806418031	806418022	749335 and after	Same as above

3. SPARE PARTS

(1) OLD TYPE

According to this modification, some of the spare parts for old type have been changed as described below.

Therefore, please order the spare parts with new numbers from now on.

No.	Nomenclature	Part No.		Interchangeability		
		New	Original			
1.	Crankshaft Assembly with bolt	881217300	810295010	Sedan Young S Truck Van	None	New(1)+(3)+(4) ↓ Original (1)+(3)+(4) Yes
			810295910	Auto-clutch		
2.	Crankshaft III with Key	881657300	813030120	Sedan Young S Truck Van	New ↑ ↓ Original	yes, but unrecom- mendable
			813030320	Auto-clutch		
3.	Piston Set I	880056007	881255000	New ↑ ↓ Original		
	Piston Set II	880066007	881265000			
4.	Needle bearing (small end)	806418031	806418022			

(2) NEW TYPE

The crankshaft for auto-clutch can be used to the Sedan, YS, Truck and Van. Therefore, only the crankshaft for auto-clutch has been prepared as the spare parts for each model. The crankshaft

assembly and crankshaft III for each model should be ordered with the following parts numbers instead of the parts numbers described in item 2.

Crankshaft Assembly	810297300	810297200
Crankshaft III with Key	881657300	813036800 813037300

(3) OVERSIZE PISTON

Oversize pistons for old and new types should be ordered with the following parts numbers.

Piston Set I	Part No.		Interchangeability
	New	Old	
O.S. 0.25mm	880057111	880050141 881255001	<div style="display: flex; align-items: center; justify-content: center;"> Yes <div style="text-align: center;"> <p>New</p> <p>↑</p> <p>↓</p> <p>Old</p> </div> None </div>
O.S. 0.50mm	880057112	880050142 881255002	
O.S. 0.75mm	880057113	880050143 881255003	
O.S. 1.00mm	880057114	880050144 881255004	
O.S. 1.25mm	880057115	880050145 881255005	

Piston Set II	Part No.		Interchangeability
	New	Old	
O.S. 0.25mm	880067111	880060141 881265001	<div style="display: flex; align-items: center; justify-content: center;"> Yes <div style="text-align: center;"> <p>New</p> <p>↑</p> <p>↓</p> <p>Old</p> </div> None </div>
O.S. 0.50mm	880067112	880060142 881265002	
O.S. 0.75mm	880067113	880060143 881265003	
O.S. 1.00mm	880067114	880060144 881265004	
O.S. 1.25mm	880067115	880060145 881265005	